

**GRIMME**  
HARVESTING SUCCESS!

# Multi-Trailer 190/350

Bulk bed with unloading belt for professional and gentle transportation of potatoes and other agriculture goods



# Gentle and powerful: the Grimme Multi-Trailer!

This machine is the optimized combination between high unloading capacity and smooth product handling. The system is designed by our daughter company Spudnik in North America where thousands of these

beds were sold. It is further developed for the European market to fit the unit on chassis from various manufacturers. The specific design provides high stability with very low machine weight and allows high payloads. Double drive pulleys on

both sides of the belt provide a safe, non-slip, high capacity discharge and especially a gentle handling of the loaded goods.

## MULTI-TRAILER

### Benefits

- A** Low dropping height: easy and gentle loading due to full length side door.
- B** We set the standard: high unloading capacity through largest unloading door in the market.
- C** Fits flexible: on chassis of different manufacturers. So you decide based on the primary use on the road or on the field.
- D** With appropriate tires on the chassis the ground pressure is significantly reduced compared to the conventional trucks.

*In fact of the hydraulic full length side door (1) (option: foldable on both sides) the loaded goods can be overload smooth with less drop than conventional trailers.*

*The tapered design of the bulk bed makes a better product handling possible.*

*The crop is well protected during transport by the standard cover.*



*The height of the side door is about 700 mm which significantly reduces loading drop (2).*

*Better product care by PE-covered sides (3). A seal over the 75 cm wide belt conveyor is responsible providing a tight seal to the belt so no dirt or grain will get into the belt drive.*

*No turkey roost needed on top of the belt for a reliable unloading even in sticky soil conditions.*





The flexible implementation in different harvest and transport chains allows a multi-purpose use.

Even with the high payload capacity the Multi-Trailer allows to unload in low buildings (4).



The hydraulic motors on both ends of the belt providing a powerful drive. All functions are activated from the drivers cab or at the rear end of the trailer (5).

The 1,1 m<sup>2</sup> large rear door (6) allows a fast and smooth unloading. Long overloading distance for better filling of the receiving line.



Two sizes – various transport facilities: the Multi-Trailer 190...

...and the Multi-Trailer 350.

## Technical data

	Multi-Trailer 190	Multi-Trailer 350
<b>Hopper volume</b>	19 m <sup>3</sup>	35 m <sup>3</sup>
<b>Body external dimension</b>		
Length (A)	6.100 mm	9.200 mm
Width (B)	2.530 mm	2.530 mm
Height (C)	2.200 mm	2.200 mm
<b>Body internal dimension</b>		
Length	5.900 mm	9.100 mm
Width	2.300 mm	2.300 mm
Height	2.000 mm	2.000 mm
Weight	2.170 kg	3.300 kg
Discharge length (D)	900 mm	900 mm
Belt width	760 mm	760 mm
Foldable side door height (E)	700 mm	700 mm

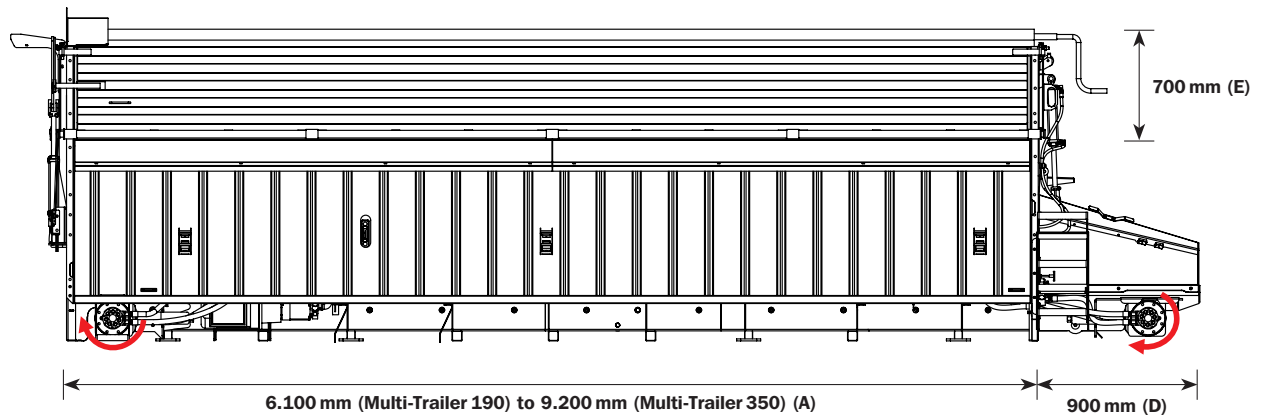
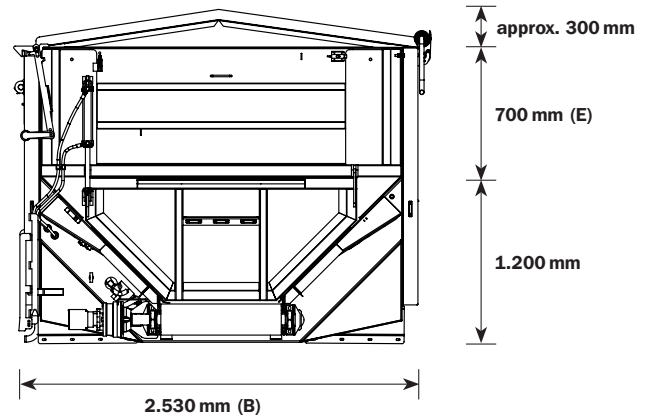

Your Grimme Partner for advice and service:

Grimme Landmaschinenfabrik GmbH & Co. KG · Hunteburger Straße 32 · D-49401 Damme  
 Phone +49 5491 666-0 · Fax +49 5491 666-2298  
 grimme@grimme.de · www.grimme.com

**GRIMME**  
 HARVESTING SUCCESS!